



# IC for Electronic Ballasts

## Short Description

The bipolar monolithic integrated circuit triggers, monitors and turns-off RF-oscillation of an electronic ballast for fluorescent lamps dependent on several control- and monitoring functions.

## Features

- Minimum wiring complexity
- Overtemperature protection without external components
- Malfunction detection
- Timer output
- Automatical re-ignition after lamp change

## Package

- DIP 8

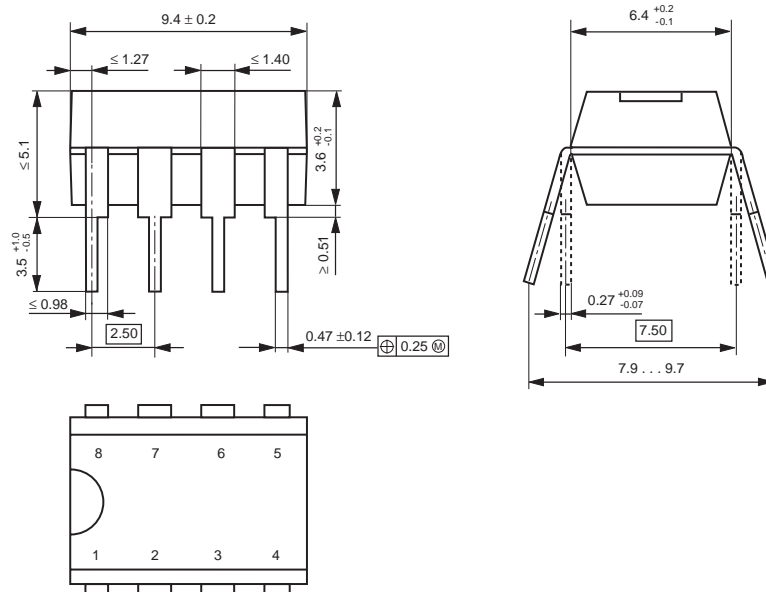

- SOP 8

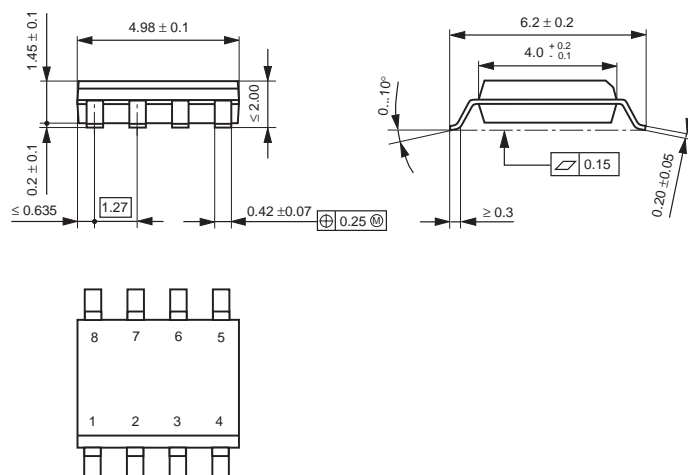

## Pinning

Pin 1	TM	temperature mode selection
Pin 2	CT	clock generator
Pin 3	TR	trigger output, turn-off attenuation, oscillation detector
Pin 4	GND	connection to ground
Pin 5	EI	error indication input
Pin 6	LW	input of lamp change
Pin 7	S	switching output of the timer
Pin 8	V <sub>CC</sub>	supply voltage

## Block Diagram

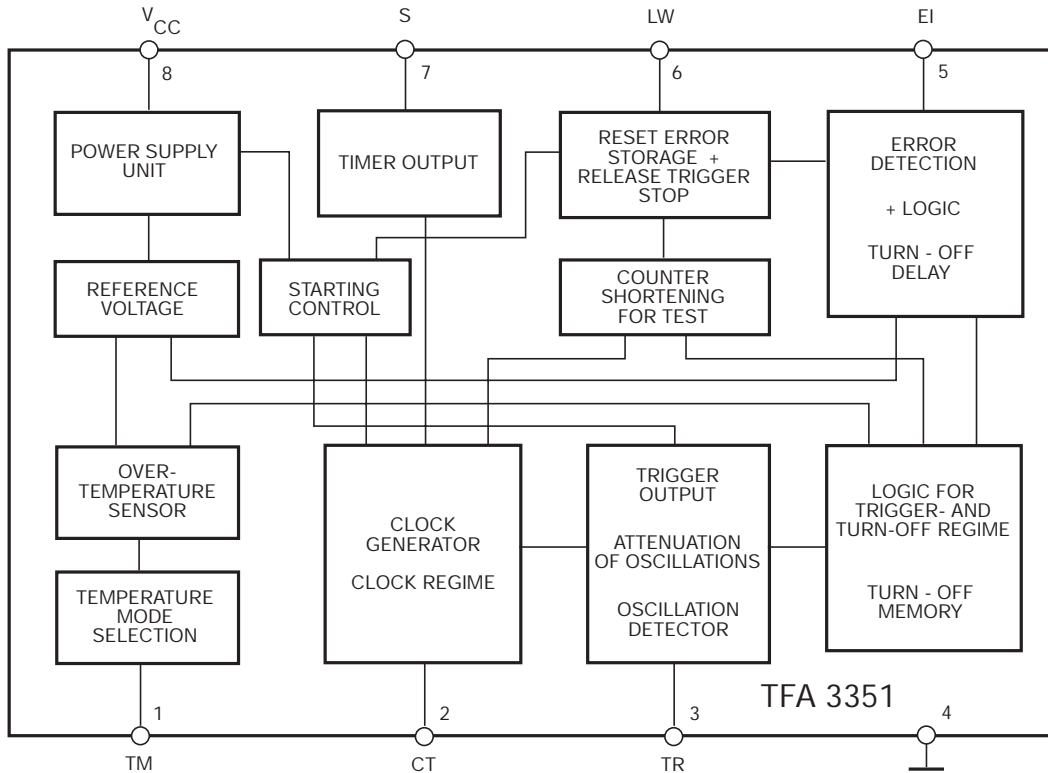

## Characteristics of the IC TFA3351

- The TFA3351 is a control- and monitoring-IC to drive an electronic ballast for fluorescent lamps.
- The IC actuates the oscillation of a self-oscillating circuit for generation of RF-shaped lamp current by means of trigger pulses. After successful excitation the oscillation is monitored and further trigger pulses are blocked.
- The IC has a timer with low-active output which is activated for one second after supply voltage was applied. The switching output is effective for pre-heating and ignition systems.
- The IC consists an error indication input. In case of error indication the IC stops oscillation. Enquiry cycles realize interference reduction.
- After lamp change the IC starts oscillation again.
- The IC protects from overtemperature cutting oscillation. It is programmable when the oscillator circuit shall be triggered again.

## Functional Description

At the moment of current feeding at terminal  $V_{CC}$ , the IC generates the supply voltage via backup capacitor externally connected. As soon as an internal switching threshold of 7 V is reached, trigger pulses are delivered at the output TR with a repetition instalment of 960  $\mu$ s. After successful triggering of the oscillator circuit, an oscillation detector guarantees blocking of further trigger pulses. It identifies a stable oscillating process, after a minimum of oscillations is detected per timing.

As soon as a switching threshold of 8 V is reached, all logic units are reset and the timer output S is activated as well. The IC starts a counter, which interrupts the control after one second.

Furthermore, the IC monitors the temperature and the oscillation circuit from a supply voltage of 8 V.

The comparator input EI is useful for error detection. Voltage > 250 mV, applied at EI, are evaluated as error signals. The error signal is enquired and registered within a cycle repeating every 960  $\mu$ s. After registration of the error signal, a counter starts to generate a delay of one second. After this delay time, the voltage at EI is evaluated again.

The error storage is set only after a second error, appearing within a directly following evaluation cycle. This error storage is resettable by a short-time power supply disconnection, or with input LW connected via a change of lamp.

The error storing causes the cutting further triggers and the control of the turn-off transistor as well, which turns the output TR to ground. Therefore, the turn-off transistor prevents the control of the oscillator circuit, attenuating it extremely quickly.

Thereby, the current consumption increases by the control of the turn-off transistor. This current amounts more than 5 mA, that the supply voltage across the backup capacitor at pin  $V_{CC}$  breaks down (because nominal current feed is less 5 mA). With a switching threshold of 6 V, the control current of the turn-off transistor is switched off, that enables the supply voltage to rise up to the limiting voltage. Because the trigger pulse gate, blocked by the error memory, the oscillation can't start again.

With error storing and attenuation of the oscillation by overtemperature it can be defined via selection of the temperature mode, whether the oscillation is automatically triggered after cooling-down of the assembly, or only after mains disconnection.

## Pin Description

Pin 1            TM            Temperature mode selection

As soon as the chip temperature range of 95 °C to 115 °C is reached, the error storage is set. When input TM is open, the error storing happens only after identification of an overtemperature and a second enquiry, delayed by one second but showing the same result and causing attenuation of the oscillation.

The multiple enquiry reduces the possibility of coupling in distortions for temperatures in the close neighbourhood of the temperature switching level.

A new start is only possible after turn-off the mains voltage.

When the input TM is connected to ground, the IC triggers the oscillation again after approximately 10 degrees decreasing of the chip temperature. Please note, that no enquiry cycle is duty in this mode.

Pin 2            CT            Clock Generator

A clock generator delivers clock pulses of 10  $\mu$ s pulse width and a repetition frequency of 33 kHz by means of defined reversing charges of the ramp capacitor connected at pin CT with a nominal value of 82 pF.

All time lapses within the IC are derived from this clock. A variation of capacity of the external capacitor affects all time responses except the trigger pulse width.

Pin 3            TR            Trigger and Turn-off Output

This pin realizes three functions:

- Delivery of trigger pulses with a repetition interval of 960  $\mu\text{s}$ , a pulse width of 1  $\mu\text{s}$  and a current flow of 600 mA with 10  $\Omega$  resistance.
- Monitoring of the control signals up to a frequency of 100 kHz and a minimum amplitude of 400 mV. The oscillation detector gates trigger pulses, if a minimum three period burst indicated during the trigger pulse repetition rate.
- Attenuation of the oscillations by a turn-off transistor with a low saturation voltage.

Negative pulses may be applied at pin TR according the specification. Negative voltage peaks can cause an increase of the current consumption. An external Schottky diode between TR and ground prevents this.

Pin 4            GND            Connection to ground

Pin 5            EI            Error Indication

At pin 5 it is possible to indicate different error values.

A static error signal greater than 250 mV, which is supplied by a suitable network at pin 5 releases after one second by means of an error enquiry cycle the storage of the error.

Furthermore the IC allows to supervise high-frequency oscillations.

An elaborate enquiry routine has been set up for secure and reliable acquisition of errors under consideration of distortions. This routine consists of the valuation time of 840  $\mu\text{s}$  with following evaluation time of 120  $\mu\text{s}$ . These two periods make the enquiry cycle repeating continuously, when no error signal is stored.

Signals with an amplitude > 250 mV and a minimum duration of 1  $\mu\text{s}$  are valued as errors. If such events happen at least 4 times within a time window of 840  $\mu\text{s}$ , or a level > 250 mV is statically applied, a counter starts to realize a delay time of one second.

If those signals are detected again in the following valuation cycle, the error memory is set.

This enquiry system saves that the RF-amplitude of the oscillating frequency is supervised, so that feed backs of damaged lamps on the oscillation circuit would be detected. A valuation threshold of 250 mV is choiced because of the low ohmic sense resistor, i.g. the emitter resistor of the ground connected switching transistor.

The kind of lamp damage is depending on the type and sample of lamp. That is the reason for an adaptive network for error detection, therefore the input EI is universal applicable.

Pin 6            LW            Input of Lamp Change

This input serves to detect a lamp change and cause a re-start with simultaneous reset of the error memory.

Input LW detects whether a lamp is connected, when a voltage > 4.25 V is applied.

A voltage < 3.25 V indicates a lamp as removed.

Is a lamp exchanged after a stored error, the error memory is reset and the trigger stop is activated.

The circuit is blocked without lamp. By removal a lamp the trigger gate is opened.

With a normal lamp change under operational conditions, triggers are continuously generated with lamp removed, therefore, the circuit starts oscillation immediately by exchange of lamp.

The switching level for lamp change will be provided by a special circuitry.

For internal testing purposes at the input LW will be applied a special test level that decreases the internal time response by factor 16.

This divider factor is active, if  $V_{LW}$  is more than 2 V above  $V_{CC}$ , but limited by max. 15 V. Pay attention that the voltage difference between  $V_{CC}$  and  $V_{LW}$  do not has to increase above 6 V also in case of supply voltage break down.

Pin 7            S            Switching Output

The switching output enables the control of the preheat duration of the coiled filament by means of an additional circuit to be selected by the customer.

The switching output is an open collector output which is low active for one second during the phase of start. It is able to drive a maximum current of 1 mA at a typical saturation voltage of 200 mV.

Pin 8                    VCC                    Supply voltage

The voltage at the  $V_{CC}$ -terminal is limited at typ. 11 V by the internal power supply circuit. Therefore it is possible to apply the power supply directly by mains with dropping resistor and backup capacitor. The current feed should be choiced high enough for the operation of the voltage limiting. For save operation of the IC the value of  $V_{CC}$  has to be never decreased behind a level of 6.5 V. An additional requirement is the increasing of  $V_{CC}$  over 8 V at least for a moment. Only under these conditions a proof error storage and a defined reaction of the turn-off transistor is guaranteed.

### Absolute Maximum Ratings

	Pin	Symbol	min	max	unit
current consumption	$V_{CC}$	$I_{CCeff}$		20	mA
peak current for $t < 100 \mu s$	$V_{CC}$	$I_{CCM}$		100	mA
input voltage error indicator	EI	$V_{Err}$	-0.3	$V_{CC}$	V
input voltage lamp exchange input	LW	$V_{LW}$	-0.3	15	V
voltage difference between $V_{LW}$ and $V_{CC}$ for divider factor 16 via LW	LW	$V_{LW} - V_{CC}$		6	V
input current at pin TM	TM	$I_{TM}$		1	mA
negative current load for $t < 1 \mu s$ with max. repeat frequency = 200kHz	TR	$I_{TR(neg.)}$	-500		mA
switching output current	S	$I_S$		1	mA
junction temperature		$T_j$		150	°C
storage temperature		$T_{stg}$	-50	150	°C
ambient temperature		$T_{amb}$	-20	120	°C
ESD protection		$V_{ESD}$		2	kV

## Characteristics

with  $T_{amb} = 25\text{ }^{\circ}\text{C}$ ,  $V_{CC} = 10\text{ V}$ , unless specified otherwise

	Pin	Symbol	min	typ	max	unit
range for internal voltage limitation	$V_{CC}$	$V_{lim}$	10.8	11.4	12	V
quiescent current consumption	$V_{CC}$	$I_{CC(on)}$		1.25	1.5	mA
trigger repeat rate with $C_{Clock} = 82\text{pF}$	TR	$t_{TRW}$	900	1000	1100	$\mu\text{s}$
output pulse current on $10\ \Omega$	TR	$I_{TRM}$	400	650	850	mA
output pulse width with 90% amplitude	TR	$t_{TR}$	0.6	0.9	1.5	$\mu\text{s}$
saturation voltage of turn-off transistor with $I=450\text{ mA}$	TR	$V_{TRsat}$		380	500	mV
saturation voltage of switching output	S	$V_{Ssat}$		0.2	0.45	V
response level of error voltage	EI	$K_{OL}$	230	250	275	mV
switching point of overtemperature turn-off		$T_S$	95	105	115	$^{\circ}\text{C}$
switching range to indicate a lamp as removed	LW	$V_{LE}$			3.25	V
switching range to indicate a lamp as applied	LW	$V_{LV}$	4.25		$V_{CC}$	V

**Values for Information ( $C_{\text{Clock}} = 82 \text{ pF}$ )**

Threshold for connecting the trigger pulses during build-up phase	7	V
Threshold for release of the internal reset	8	V
Threshold for switching-off the control of the turn-off transistor with set error memory	6	V
Delay of response with error detection	1	s
Duration for activation switching output	1	s
Duration needed for rating at least 4 pulse-shaped distortions or a static error signal with twice interrogation within delay time 1 sec	840	$\mu\text{s}$
Control current of the turn-off transistor	10	mA
Temperature hysteresis for re-ignition after overtemperature switch-off ( pin TM is connected to ground )	10	$^{\circ}\text{C}$

## Dependences

Current consumption vs. supply voltage

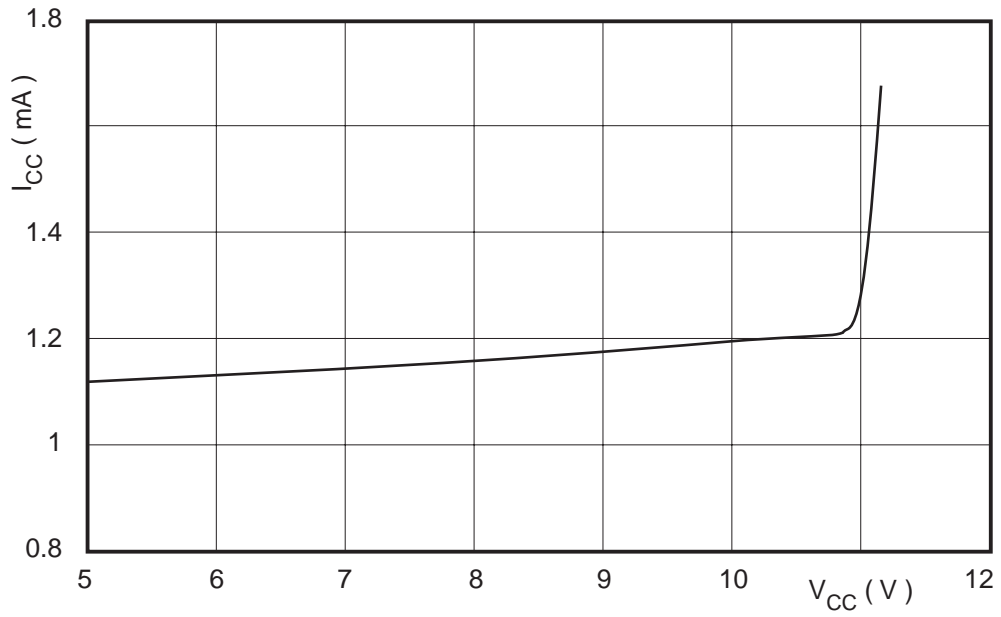

Voltage limiting vs. temperature  
 $I_{CC} = 5 \text{ mA}$

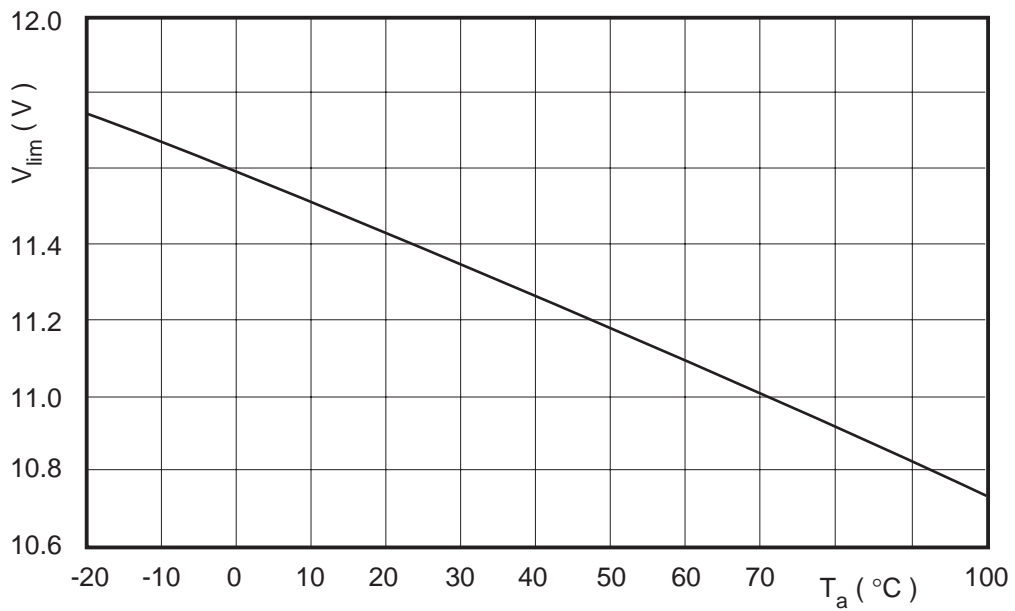

Trigger current at 10  $\Omega$   
vs. temperature,  $V_{CC} = 10\text{ V}$

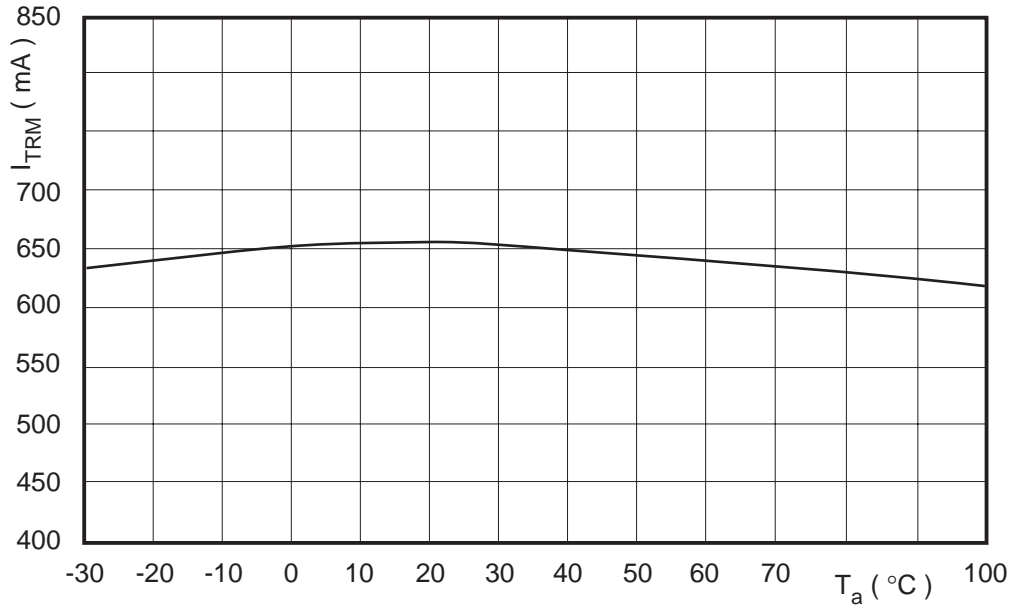

Trigger pulse width (90% amplitude)  
vs. temperature,  $V_{CC} = 10\text{ V}$

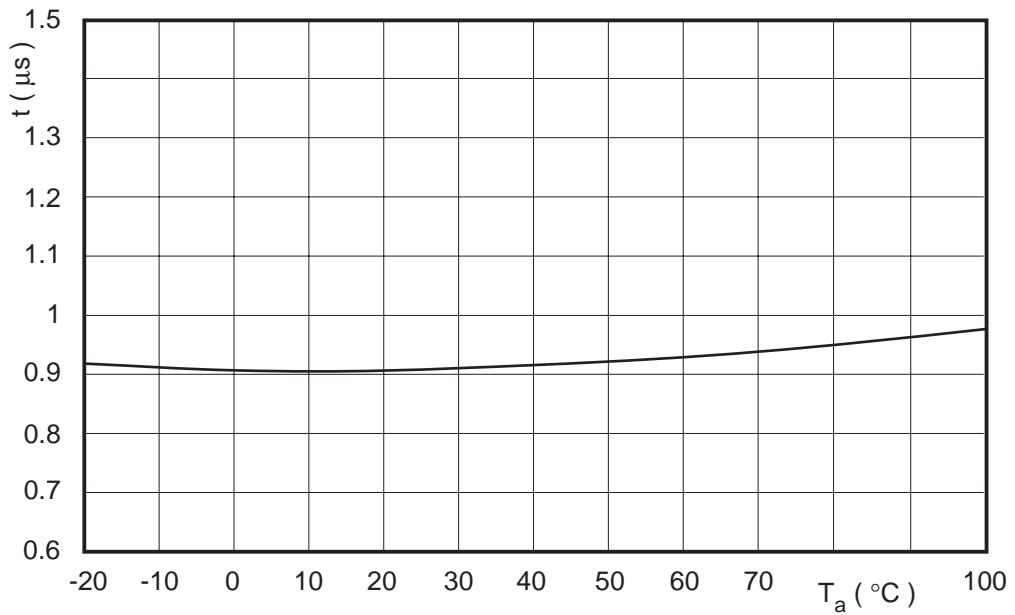

Static overload threshold  
 $V_{CC} = 10\text{ V}$

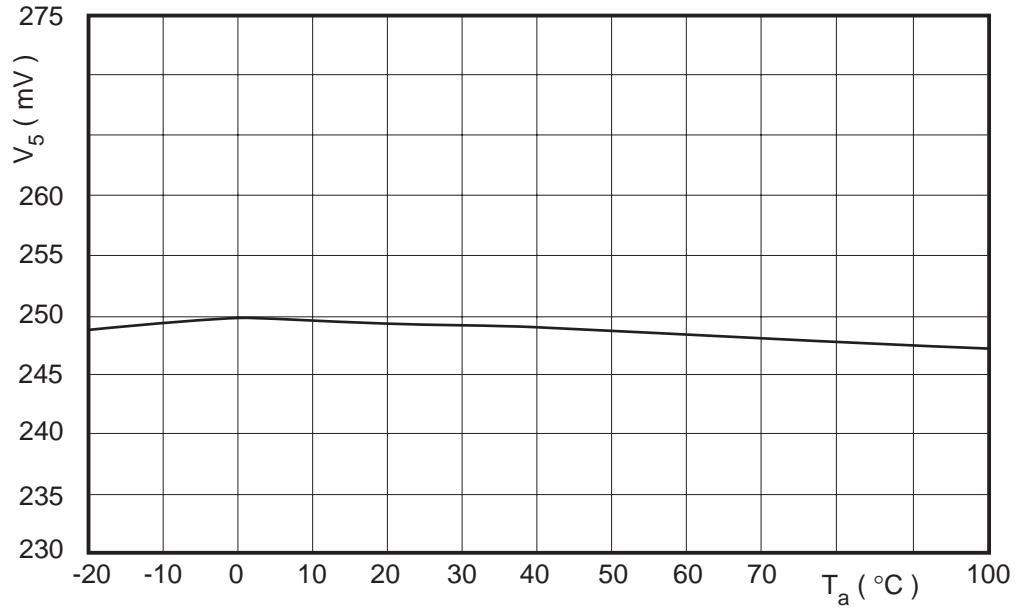

Timer output saturation voltage at 1mA  
 $V_{CC} = 10\text{ V}$

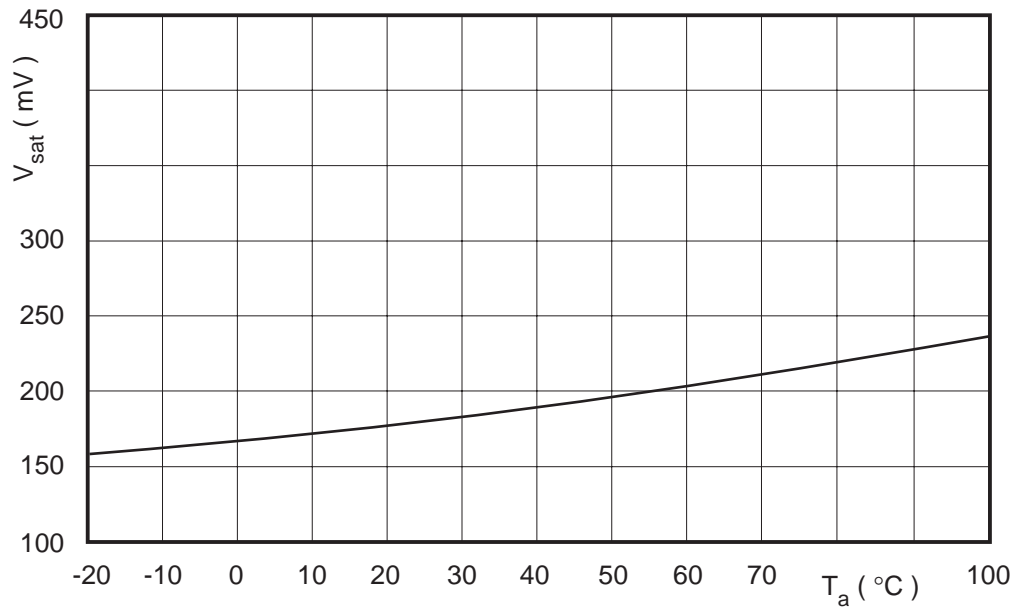

## Principle Circuit Diagram

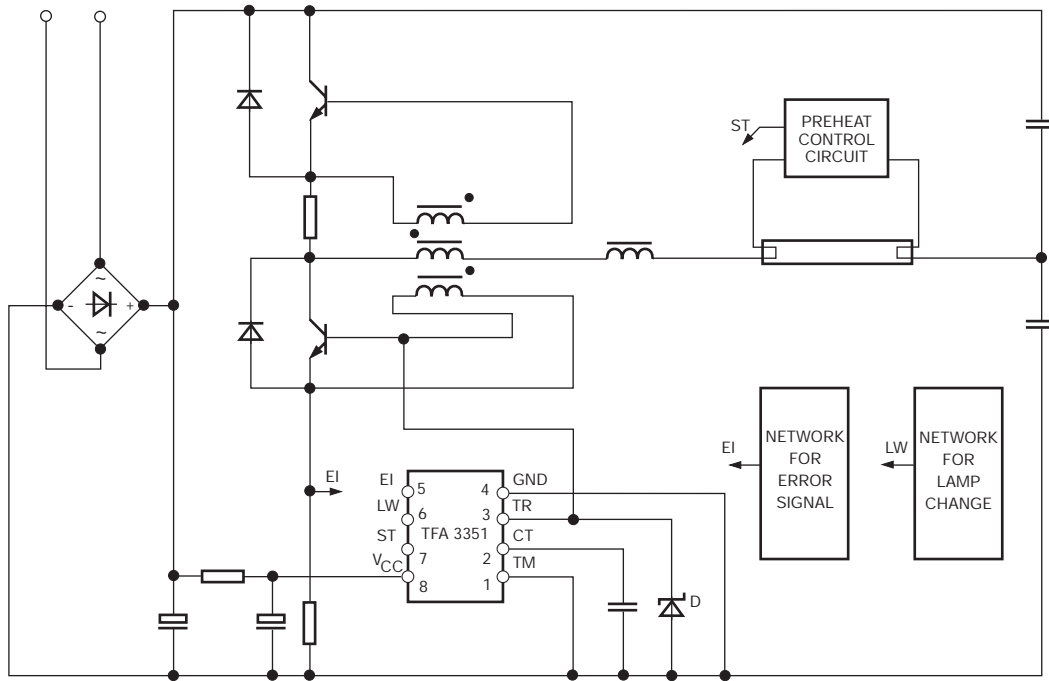

## Application Example

