

ISDN Power Feeder with 3.3V Logic

Short Description

The integrated circuit TFB4014T with 3.3V logic interface is designed for feeding two and four wire ISDN transmission lines. The TFB4014T feeds transmission lines up to 150mA per each output. The integrated circuit is fabricated in 60V MIX technology (BCD-MOS). DMOS power transistors with current limitation, overtemperature and short current protection are used for driving the lines.

Features

- Power supply for up to four transmission lines
- Overload protection for each output
- Separate control for each output
- Maximum programmable output current limit 150mA per line
- 3.3V logic interface
- Status detection for each line output
- SOP 28

Block Diagram

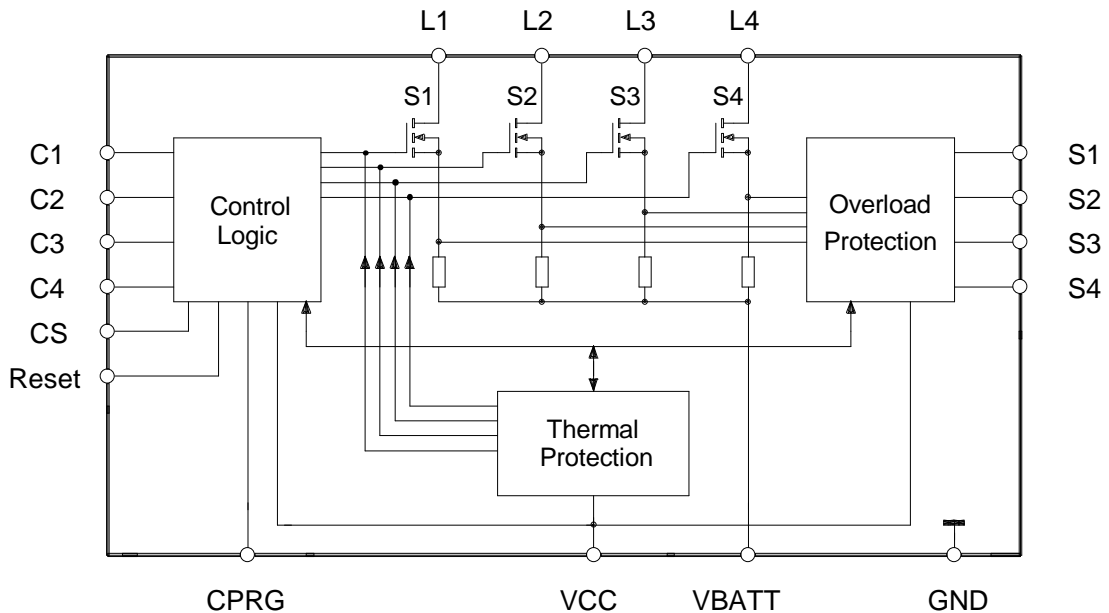

Pinning

Pin	Symbol	Function
1	V _{CC}	Positive supply voltage
2	CPGR	Current limit, programmable by external resistor
3	C2	Control input switch 2, pull down
4	S2	Output status detection switch 2, pull up
5	L2	Feeding output switch 2
6	V _{BATT}	Negative supply voltage
7	V _{BATT}	Negative supply voltage
8	V _{BATT}	Negative supply voltage
9	V _{BATT}	Negative supply voltage
10	L3	Feeding output switch 3
11	S3	Output status detection switch 3, pull up
12	C3	Control input switch 3, pull down
13	n.c.	-
14	CS	Input chip select, pull up
15	RST	Reset input, pull up
16	n.c.	-
17	C4	Control input switch 4, pull down
18	S4	Output status detection switch 4, pull up
19	L4	Feeding output switch 4
20	V _{BATT}	Negative supply voltage
21	V _{BATT}	Negative supply voltage
22	V _{BATT}	Negative supply voltage
23	V _{BATT}	Negative supply voltage
24	L1	Feeding output switch 1
25	S1	Output status detection switch 1, pull up
26	C1	Control input switch 1, pull down
27	TP	Test pin, don't connect
28	GND	Ground

Functional Description

The TFB4014T is designed to feed the S₀ and U_{p0} lines in digital exchanges. The IC includes four feeding output stages. Each output is able to deliver a nominal output current in the range from 50mA to 150mA. The output current limit is programmable by an external resistor connected to ground. The resistor value is calculated by:

$$R_{CPRG} = (2 * 1.25V / I_{Omax}) * 1000$$

The current limitation response time is about 100 millisecond. This delay avoids a failure detection caused by current peaks when the line outputs turn-on. All outputs are protected against overload and overtemperature.

The TFB4014T also contains a parallel logic interface to control each output stage separately. The status outputs are open collector outputs with internal 15kΩ pull-up resistors.

Functional Description (cont.)

In normal operation the feeding switches Ln are ON and the feeding current is lower than the programmed current limit. The temperature protection is not active. The status outputs Sn are LOW.

The status outputs change to HIGH if one or more of the following conditions are valid:

- Feeding switches Ln are OFF controlled by Cn.
- RESET condition (external or internal).
- Feeding switches are ON controlled by Cn, but the feeding current exceeds the programmed current limit.
- The temperature protection is active.

The temperature protection has two trip points with hysteresis. When the junction temperature reaches 145°C and output currents are higher than the programmed limit the respective outputs are switched-off. These outputs can be switched-on with a new HIGH signal at Cn after the temperature decreased.

When the temperature exceeds 155°C a RESET signal is generated internally. All outputs Ln are forced to switch-off. The outputs can be switched-on only with a new HIGH signal at Cn when the temperature dropped down.

All feeding outputs are forced to switch-off independent of the control input status, if the Reset input RST is LOW. Therefore the power transistors can not switch-on when the supply voltage ramps up. When the supply voltage raised to normal level it is possible to switch-on the outputs Ln setting the control inputs Cn to HIGH step by step, while CS = RST = HIGH.

Function Table

Function	Control Input Cn	RST	CS	Feeding Output Ln	Status Output Sn
Feeding output ON, normal mode	H	H	H	ON	L
Feeding output OFF, normal mode	L	H	H	OFF	H
RESET	x	L	x	OFF	H
Output current exceeds limit	H	H	H	ON	H
Overtemperature	H	H	H	OFF	H

Turn-on Order

	t ₁	t ₂	t ₃	t ₄	t ₅ L1 - L4 OFF	t ₆ L1 ON	t ₇ L2 ON	t ₈ L3 ON	t ₉ L4 ON
V _{BATT}	ON	ON	ON	ON	ON	ON	ON	ON	ON
RST	x	L	L	H	H	H	H	H	H
V _{CC}	x	x	ON	ON	ON	ON	ON	ON	ON
CS	x	x	x	x	H	H	H	H	H
C1	x	x	x	x	L	H	H	H	H
C2	x	x	x	x	L	L	H	H	H
C3	x	x	x	x	L	L	L	H	H
C4	x	x	x	x	L	L	L	L	L

Absolute Maximum Ratings

Absolute maximum ratings are limiting values, which can cause damage of the device with exceeding only one parameter. Absolute maximum values are valid for the operational temperature range.

Parameter	Symbol	Min.	Max.	Unit
Positive Supply Voltage	V_{CC}	-0.3	4.3	V
Negative Supply Voltage	V_{BATT}	-64	+0.3	V
Input Voltage (Cn, CS, RST)	V_I	-0.5	$V_{CC} + 0.5$	V
Output Voltage (Sn)	V_O	-0.5	4.05	V
Output Current (Sn)	I_O		15	mA
Junction Temperature	T_j		+155	°C
Storage Temperature	T_{STG}	-40	+125	°C
Ambient Temperature	T_A	-15	+85	°C
Thermal Resistance junction-ambient	R_{thja}	65		K/W
Power Dissipation	P_{tot}		1	W
ESD Voltage (1.5k, 100pF)	V_{ESD}			V
Pin 3, 12, 17, 26		-2000	+200	
Pin 14, 15		-2000	+1500	
other pins		-2000	+2000	

Recommended Operating Conditions

Parameter	Symbol	Min.	Max.	Unit
Negative Supply Voltage	V_{BATT}	-53	-36	V
Positive Supply Voltage	V_{CC}	3.0	3.6	V
Input LOW Voltage (Cn, CS, RST)	V_{IL}	0	0.8	V
Input HIGH Voltage (Cn, CS, RST)	V_{IH}	2.0	V_{CC}	V
Operating Temperature	T_A	0	+70	°C

Electrical Characteristics

$V_{BATT} = -53V$, $V_{CC} = 3.6V$, $R_{CPGR} = 16k\Omega$, $T_A = 0^\circ C$ to $+70^\circ C$, if not otherwise specified

Parameter	Symbol	Min.	Max.	Unit
Positive Supply Current all outputs Ln ON, $I_{Ln} = 100mA$	I_{CC}		7	mA
Negative Supply Current all outputs Ln OFF, $V_{BATT} = -64V$	I_{BATT}	-2.5		mA
Input HIGH Voltage (Cn, CS, RST)	V_{IH}	2.0		V
Input LOW Voltage (Cn, CS, RST)	V_{IL}		0.8	V

Electrical Characteristics (cont.)

$V_{BATT} = -53V$, $V_{CC} = 3.6V$, $R_{CPGR} = 16k\Omega$, $T_A = 0^{\circ}C$ to $+70^{\circ}C$, if not otherwise specified

Parameter	Symbol	Min.	Max.	Unit
Input HIGH Current (Cn, CS, RST) $V_{IN} = 2.0V$	I_{IH}		200	μA
Input LOW Current (CS, RST) $V_{IN} = 0.8V$	I_{IL}	-200		μA
Output LOW Voltage (Sn) $I_{OL} = 3mA$	V_{OL}		0.4	V
Output HIGH Voltage (Sn)	V_{OH}	3.1		V
Output OFF Current (Ln) $V_{Ln} = 0V$	I_{OFF}		100	μA

Package

SOP 28

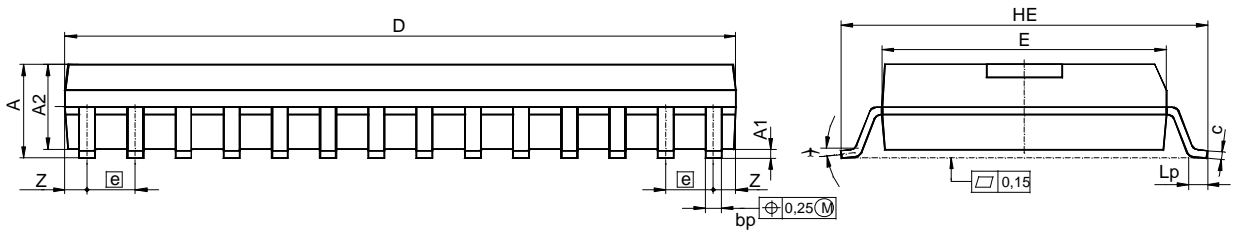

Symbol	Dimensions in mm		
	min	nom	max
A	-	-	2.65
A1	0.1	-	0.3
A2	2.25	-	2.4
bp	0.35	-	-
bp	-	-	0.49
c	0.23	-	0.32
D	17.9	-	18.1
E	7.4	-	7.6
e	-	1.27	-
HE	10.2	-	-
HE	-	-	10.6
Lp	0.3	-	-
Z	-	-	0.82
θ	0°	-	10°
n	-	28	-